

Small Range 6.26

CLASSIC 52

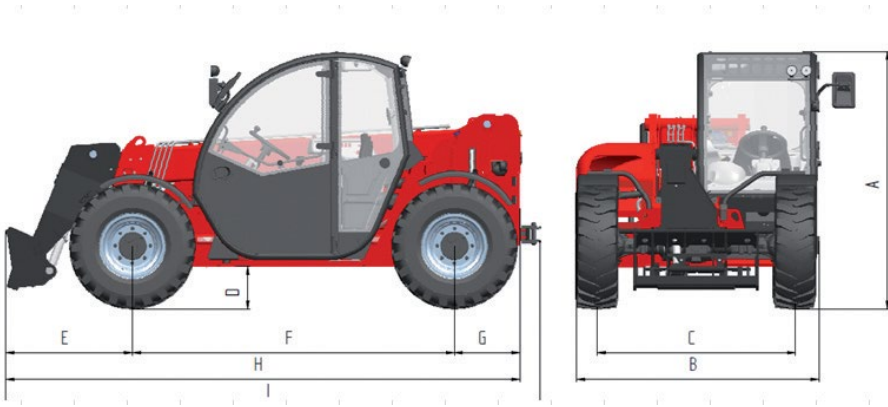

DIMENSIONS (mm)		6.26
A. Height		1935
B. Width		1890
C. Gauge		1550
D. Ground clearance		220
E. Front overhang		990
F. Pitch		2525
G. Rear overhang		520
H. Length without towing hook		4035
I. Length with towing hook		4198
L. Cabin width		960

Dimensions defined on model with wheels 12-16.5

Load diagram

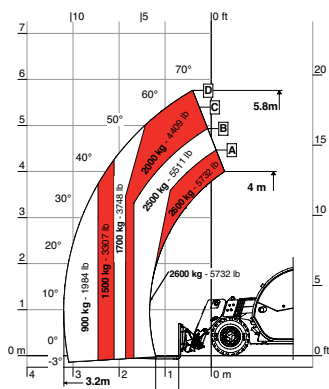

6.26

MODELS	6.26
WEIGHT	
Maximum total unladen weight (kg)	4700
SPECIFICATIONS	
Number of extracting sections	1
Maximum capacity (kg)	2600
Maximum lifting height (mt)	5,9
Maximum horizontal boom extension (mt)	3,2
Boom extension at max height (mt)	0,3
Forks swinging angle (°)	155
TANK CAPACITY	
Hydraulic oil tank (l)	70
Diesel oil tank (l)	80
CONNECTION FOR EQUIPMENT	
	FH

CONFIGURATION	CLASSIC 52
Engine (kW/hp)	Yanmar 51,7/69,3 IIIB/Tier4
Transmission	Hydrostatic
Service pump (l/min)	Gears 80 l/min@230 bar
Joystick	Mechanical electro-proportional
Traction power (kg)	3530
Display	Multi-function
Queen cab cabin	standard
Front and rear LED lights	optional
Manual 6-way diverter	optional
Rear hydraulic connection with dual electro proportional effect	optional
Rear trailer lights socket	optional
Engine water pre-heating	optional
Air conditioning	optional
Hydraulic trailer brakes	optional
Pneumatic trailer brakes	optional
Boom suspension	optional
Floating boom	optional
PEB manual 6-way diverter	optional
Wheels 12-16.5	standard
Wheels 12.5-18	optional
Creeper	optional
Front constant flow	optional
Bucket mode	standard
Quick release	optional